

A : 1350 / 1350 + "Hub" 1650 = 3000 mm

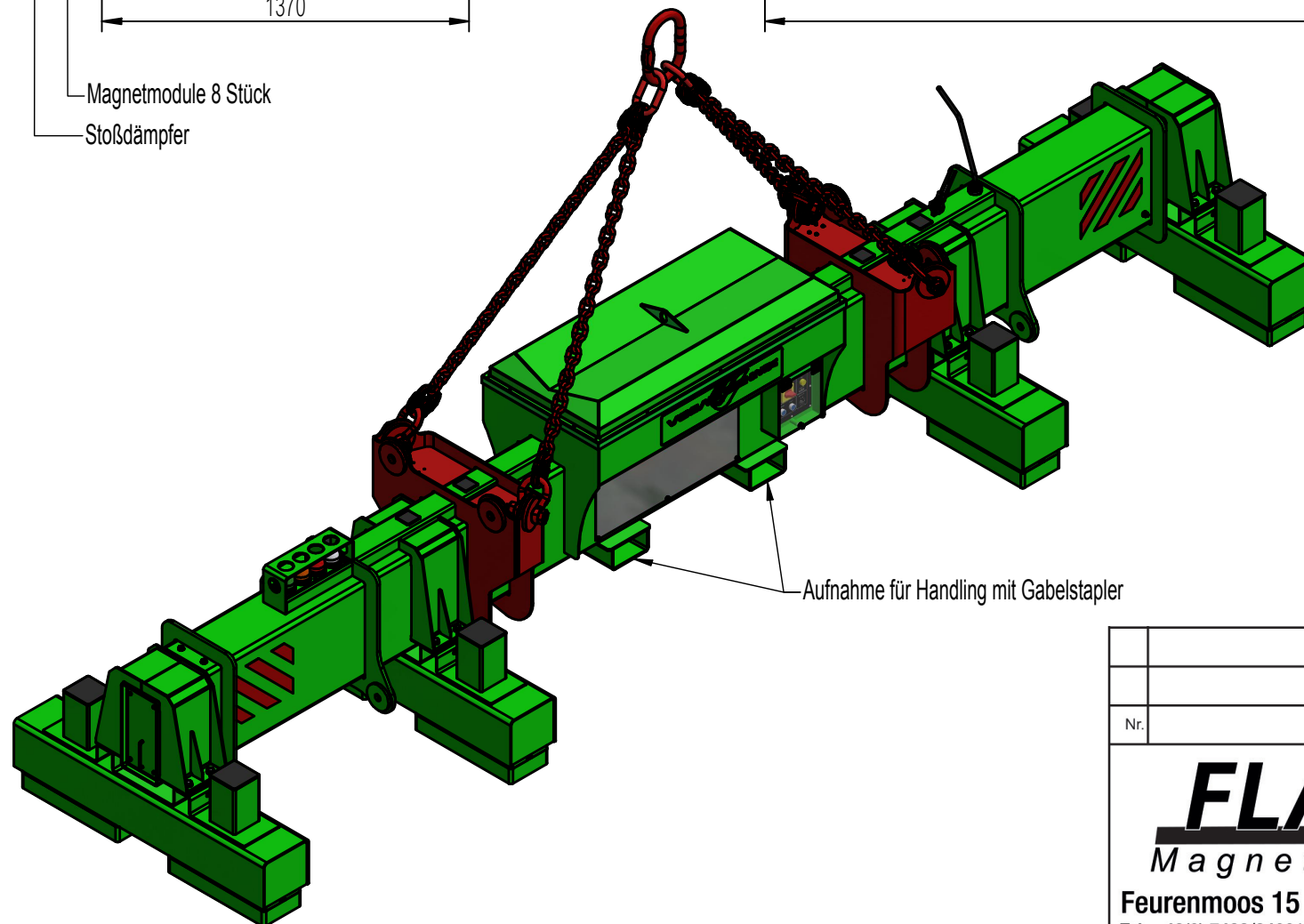

**Handling einzelne Bleche vom Stapel**

- Länge = 3000 ÷ 12000 mm
- Breite = 500 ÷ 3500 mm
- Materialstärke = "s" min. mm

Modell : type		
"xxx"	WLL (kg)	"s"
110	11000	5
140	14000	5
165	16500	5
200	20000	8

				Gezeichnet	Geprüft
Nr.	Änderung	Tag			
<b>FLAIG</b> <b>Magnetsysteme</b> Feurenmoos 15 • D 78739 Hardt Tel. +49(0) 7422/940010 • Fax +49(0) 7422/9400125 EMail: info@flaig-te.de • www.flaign-te.de		Werkstoff:	Freimaß-toleranz	Maßstab	Geräte-Nr.
		<b>FXE-TT 4-XXXX</b>			Blatt-Nr.
				Teil-Nr.	